

Instruction Manual for FALCONEYES DPT386AFZ series

Thank you for purchasing FalconEyes' products.

This is an innovative designed electronic flashgun for both digital cameras and film cameras. The features are leading photography into digital era.

Advanced technology is used in the flashgun to control the correct amount of light output. Please kindly take few minutes to read the instruction manual before using.

Digital TTL / Auto Focus flash for:

C - Canon Digital E-TTL, E-TTL II cameras & E-TTL film cameras

S α - Sony Alpha & Minolta Digital ADI, D Lenses cameras & TTL film cameras

N - Nikon Digital TTL, i-TTL cameras & TTL, i-TTL film cameras

O - Olympus Digital cameras

P - Pentax P-TTL Digital & film cameras

CHARACTERISTICS

- LC Display
- Auto and manual zoom from 24-28-35-50-70-85mm
- Red focus assist beam for low light focusing
- TTL metering
- Automatic shutter speed setting
- 5 level of power ratio 1/1, 1/2, 1/4, 1/8, and 1/16
- Flash readiness indication in viewfinder
- Front and rear curtain synchronization
- Red eye reduction (for Nikon, Olympus and Pentax)
- Built-in slave function
- Built-in reflecting plate and diffuser
- Power saving function

SPECIFICATIONS

Guide Number (ISO 100)	38(m)/125(ft) at 85mm position
Motor zooming reflector	24 - 28 - 35 - 50 - 70 - 85mm
Power Source	4x 1.5V AA size alkaline batteries
Flash Duration	1/1,000 - 1/20,000 second
Recycling Time	0.5 - 9 seconds
Number of Flashes	80 times with fresh alkaline batteries
Color Temperature	Daylight
Dimensions	Approx. 72 x 100 x 125 mm
Net Weight	Approx. 270 grams (w/o batteries)

* Specifications are subject to change without further notice.

* For Minolta Dynax 3 and 5, select WL from functional dial to on position before using DPT386AFZ-S α .

LOADING BATTERIES

- Make sure the main switch at "OFF" position
- Slide the battery compartment cover forward and swing open
- Insert batteries according to the indicated "+/-" symbols
- Close the compartment cover and slide it back to lock in place
- Ensure all batteries must be of same make and have the same charge level, alkaline batteries are preferable

MOUNTING THE FLASHGUN ON THE CAMERA

- Switch off the flashgun and the camera
- Turn the knurled nut of the flashgun right up against the flashgun
- Slide the flashgun into the camera's accessory shoe
- Turn the knurled nut of the flashgun against the camera, thereby flashgun clamped on the camera
- For Type S α . Insert the Mounting Foot of the flashgun into camera accessory shoe. Then the flashgun is locked in place.
- For Type O. Insert the Mounting Foot of the flashgun into camera accessory shoe and press "LOCK" to lock the flashgun in place.

REMOVING THE FLASHGUN FROM THE CAMERA

- Switch off the flashgun and the camera
- Turn the knurled nut right up against the flashgun
- Remove the flashgun from the camera accessory shoe
- For Type S α . Push the Shoe Release Button and pull the flashgun off backward.
- For Type O. Press both sides of the Lock/Release Button towards the directions as indicated then pull the flashgun off backward.

ON/OFF SWITCH AND FLASH TEST OPERATION

To switch on the flashgun, slide the main switch to "ON" position. Ready indicator "READY" lights up as soon as flash readiness established. Press the Test Button to ensure the flashgun works properly. If the flashgun discharges, then wait until the "READY" light glows again. To switch off, slide the main switch to "OFF" position.

ILLUMINATION OF LC DISPLAY

LC display is used to show the general information of camera and the current status of flashgun, every time when the "LIGHT" key is lightly tapped, LC display will be illuminated for about 5 seconds.

TAKING PICTURE, AF / TTL OPERATION

Automatic flash sync speed control
When the flashgun is ready, the camera will automatically switch it to flash sync speed from program mode or aperture-priority mode selected. The sync speed depends on the camera model and usually ranges between 1/30sec to 1/250sec.
When a flash shot has been taken, "OK" symbol briefly flashes on the LC display to confirm correct exposure.

Auto-focus "AF" measuring flash
The integrated "AF" red light beam of the flashgun supports the automatic focusing of auto-focus TTL cameras. When the prevailing light is insufficient for automatic focusing, the flashgun will project a red light beam onto the object as soon as the camera's shutter is lightly touched. The camera's auto-focus system then focuses the object by this spot of red light beam.

TTL flash control
When you switch on the flashgun, it will set at TTL mode firstly and the LC display indicates "TTL". When the Ready indicator lights up, press the shutter release fully to take the picture. The advanced programming and computerized circuitry of the flashgun provide correct amount of flash light output according to the camera's exposure measurement through the lens (TTL). If you need to change the mode, simply press the mode selector.

For Canon type, this flashgun's E-TTL indicator will light while connected with E-TTL cameras.
For Nikon type, this flashgun's LC Display will show TTL, I-TTL and BL in different way while connected to different camera models. Please refer to the camera's manual.

Manual flash mode at full light output
To use the flashgun at full light output in the manual mode, the mode selector must be set to M (Manual) position. The LC display indicates M (Manual). A full-power flash will then be fired each time the flashgun is triggered. The LC display automatically shows the flash-to-subject distance required for a correct exposure. An adaptation to the individual shooting situation can be achieved by changing the lens diaphragm or the focal length (on the camera). 5 level "Power Ratio" of 1/1, 1/2, 1/4, 1/8 and 1/16 could select by slightly tapping the Mode selector when it is at the manual position.

FRONT AND REAR-CURTAIN SYNCHRONIZATION

Front and rear curtain synchronization is supported, and just simply set into Front or Rear mode in usage. For Pentax, you could select the synchronization mode as front curtain (S) or rear curtain (R). The flashgun will fire according to the mode selected to match with the camera shutter.
For Canon, Sony Alpha, Nikon and Olympus, the cameras control front or rear-curtain synchronization, therefore setting for flashgun is not required.

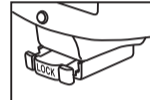
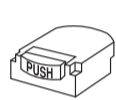
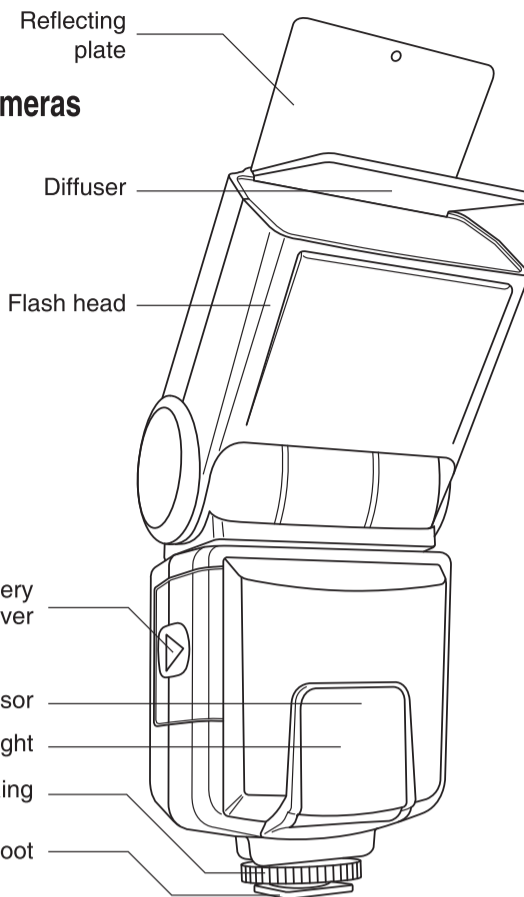

Type S α Mounting foot

Type O Mounting foot

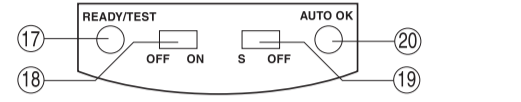
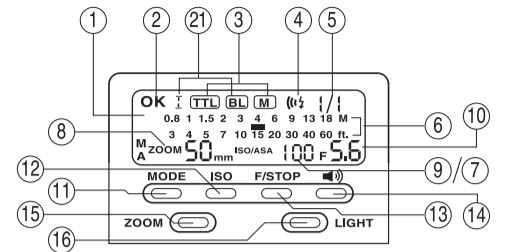

Type S α , N, O

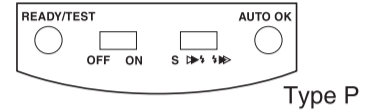

Type P

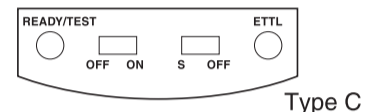

Type C

1. LC Display
2. Auto Check Indicator
3. Mode Indicator
4. Beeper Indicator
5. Power Level Setting
6. Flash Range Distance Bar
7. Power Off Indicator
8. Zoom Position
9. Film Speed Indicator
10. F-Stop Indicator
11. Mode Selector
12. Film Speed Selector
13. F/Stop Selector
14. Beeper on/off
15. Zoom Selector
16. Back Light
17. Ready / Test
18. Power ON/OFF Switch
19. Slave Mode Switch
20. Auto OK
21. Mode Indicator (N only)

BOUNCED AND SWIVELED FLASH

Photos shot with full frontal flash are easily recognized by their harsh, dense shadows. This is often associated with a sharp drop of the foreground to the background. This phenomenon can be avoided with bounced and swiveled flashgun. Because the diffused light will produce a soft and uniform rendition of the reflector is turned vertically by up to approx. 90°. So that the flashgun is bounced back from a suitable reflective surface for color shots must be white or have a neutral color and it must not structured. When swiveling the reflector ensure that no direct light from the reflector reaches the subject. When using bouncing or swiveling flash, the zooming position will be locked in 50mm, except with Manual mode.

Reflecting plate and diffuser

The flashgun has built-in reflecting plate and diffuser. You can slide out the reflecting plate or diffuser from the top of flash head. Bouncing the flash head and using reflecting plate to produce more effective looking pictures. The diffuser can reduce strong light to create soft effects.

POWER ZOOMING

Automatic motor zoom control

If you are using zoom lens, which transmit their focal length to the camera. The camera will pass on this information to the flashgun. The flashgun then automatically adjusts its zoom position to comply with the focal length of the lens. Automatic motor zooming reflector control is only possible with cameras permitting digital data transmission to the flashgun.

The LC display on the flashgun indicates zooming position of 24-28-35-50-70-85mm. When the flashgun is switched on, the activated zoom position is set at 35mm. As soon as the camera's shutter is lightly touched, the focal length of the flashgun is automatically adapted to the focal length of the lens.

Whenever flash head is not at normal position (facing to the front), such as bounced or swiveled at different position. Zoom position will be at 50mm and indicated LC display with brief flash in auto mode.

Manual motor-zoom control

The "Zoom" key permits you to change the zoom reflector's position independently of the focal length of the lens. The LC display then indicates "M" and presently adjusted zoom position of the reflector.

By slightly tapping the "Zoom" key you can select the zoom position in the following sequence: 24-28-35-50-70-85mm.

Auto Zoom position → M24 → M28 → M35 → M50 → M70 → M85 → Auto Zoom position

SLAVE FUNCTION

This flashgun can perform as a wireless slave by switching Slave Mode Switch to S position. The flashgun will automatically switch to M mode with power ratio 1:1. When the sensor detects the external flash fire, the flash will synchronize to fire. The amount of light output can be controlled by selecting the power ratio from 1/1 to 1/16. If multi-flashes are set as slave, you must consider the light amount to get the correct exposure. When the slave mode is on, the power saving mode will not function.

POWER SAVING FUNCTION

The flashgun will automatically switch off to save power around 3 minutes after:

- the flashgun was switched on
- the last flash was fired

The LCD Display "OFF" signal. To reactivate the flashgun, simply press any push buttons underneath the LC display panel or switch the main switch off and on again.

The flashgun is not completely switched off, however its power consumption is drastically reduced. If you are not going to use your flashgun any longer, set the main switch to "OFF"

SAFETY INSTRUCTION

- Do not fire flashes from a short distance directly into the eyes of persons or animals. This can cause damage to the retina and may even lead to blindness.
- Use only the power sources specified in the operation instructions.
- Never attempt to open or short-circuit batteries.
- Never expose dry or rechargeable batteries to excessive temperature such as intensive sunlight or fire.
- Always switches off the flashgun before changing the batteries.
- Do not attempt to open the flashgun because of High Voltage. There are no components inside the flashgun, which can be repaired by the user.
- If in case of the flashgun is so badly damaged that internal components are exposed, the flashgun may not be used until it has been repaired. Remove the batteries to prevent inadvertent use.
- Never try to repair the flashgun by yourself. If there are any problems, please contact the customer service.

WARNING

This flash unit may halt and could not function under the following circumstances:

1. When the battery power is not sufficient
 2. When user operates this unit in an inappropriate way
- Please switch off the flash unit by its main switch when it is not working correctly. Wait for a few seconds and replace the battery if necessary before switching it on again. The flash unit should work as normal afterward.

